



STEVENSONS
DOORS LTD.

**INDUSTRIAL &
COMMERCIAL**
PRODUCT CATALOGUE

EDITION 2

We offer 24/7 responsive service & repair /  0800 455 566

CONTENTS

03

ABOUT US

04

ROLLER SHUTTER
DOORS

06

ADDITIONAL OPTIONS

08

SWING DOORS

10

GRIFCO AUTOMATION
OPTIONS

12

HIGH SPEED RAPIDS

14

ROLLER & RETRACTABLE
GRILLES

15

SLIDING DOORS &
GATES / HANGARS

16

LIGHT COMMERCIAL
DOORS

17

SERVICING & REPAIRS

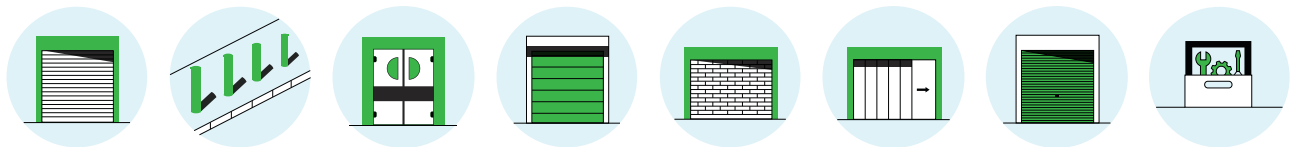

OUR PARTNERS



Nearly 30 years of innovation in door manufacturing

Since 1996, we've been pioneering product development and intelligent engineering to provide roller shutter doors renowned for their reliability and strength.

While we have nearly 30 years of experience behind us, what defines us is our ability to always be looking ahead. Our doors and manufacturing processes were designed from the ground up, by understanding what people need and offering the right solutions.

Since the beginning, we've stayed at the forefront of innovation in door and security technology, providing our customers with confidence and peace of mind by using only quality materials and partnering with industry-leading brands.

From our Palmerston North base, we manufacture doors that we distribute and install right throughout the lower North Island and beyond. We know the inconvenience and concern that comes with not having an operational door. The size of our team, the skills of our experienced technicians, and the efficiency of our operations, allow us to be highly responsive to get your door back up and rolling with minimal downtime.



ROLLER SHUTTER DOORS

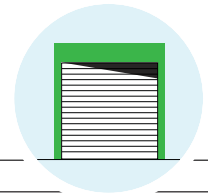

High standards of performance and durability, custom fit for your purpose & premises



Using enduring materials and innovative design processes, we've ensured our doors are made to withstand high wind loads and the demands of commercial use, with an attractive profile that doesn't compromise the exterior aesthetic of your property.

The three operation methods are:

SPRING BALANCED OPERATION

MANUAL HAND-CHAIN OPERATION

MOTORISED OPERATION

We'll recommend the right motorised control option for your requirements.

We offer a wide range of colour options to further enhance the appearance of your door.

Your selected colour is added to the door by powder-coating the individual slats before the door is installed.



BEFORE



AFTER

ROLLER SHUTTER DOORS

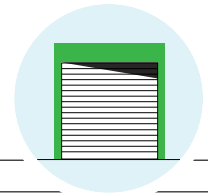

Our roller shutters are a reliable choice for security, strength and operational ease.

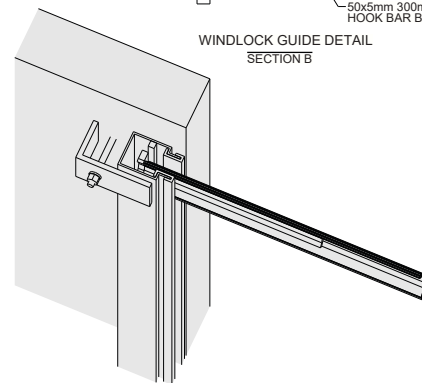
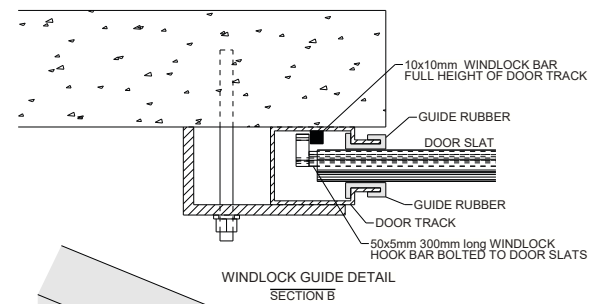
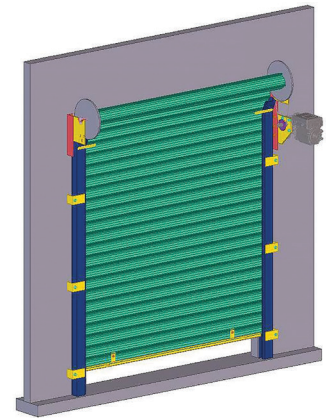
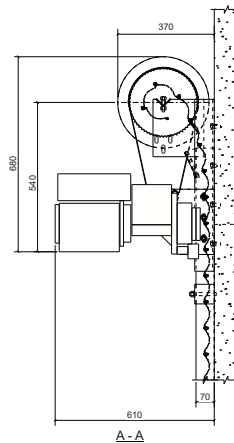
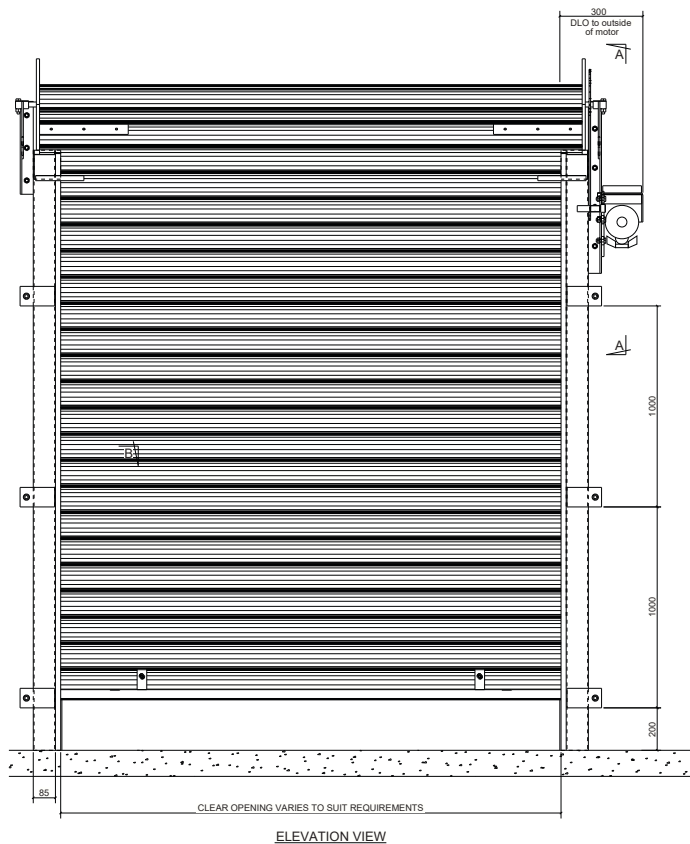

The doors are constructed from interlocking slats, roll-formed from galvanised steel coils. Due to the way the slats interlock, individual slats are able to be easily replaced, making repairs on your door straightforward and hassle free.

QUALITY GUARANTEE

With close to 30 years of experience manufacturing and installing roller doors, we stand behind our craftsmanship and our service, and the quality of the leading-brand components we supply.

MADE LOCAL

All our roller doors are manufactured in Palmerston North, using quality materials and components, and installed throughout the country by knowledgeable technicians.

ADDITIONAL OPTIONS

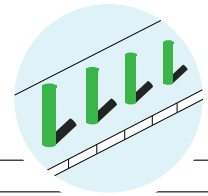

PERSONNEL ACCESS DOORS

A practical solution for when there isn't wall space for a main door, but there is a need for access in and out of the building. Integrated into the curtain, and used instead of opening the roller shutter door every time someone enters or exits the building.

VENTILATION SLATS

Ideal where vision is required or where airflow is important due to the presence of gases or fumes. The ventilation slats allow these undesirable gases and fumes to escape, and clean air to come into the building, all without compromising security.



SLIDING WIND BRACE

With doors over 7m wide and doors in high wind areas, it is recommended to reinforce your roller shutter door. A sliding wind brace is a vertical support that takes the impact of wind loading off the roller shutter door, enhancing the overall structural integrity, and longevity of your door.

BOLLARDS

Improve area safety with bollards to provide a visible, physical barrier to protect people, buildings, materials, equipment, doors and more against vehicle damage; eliminating serious injuries or the need for expensive repairs.



ADDITIONAL OPTIONS

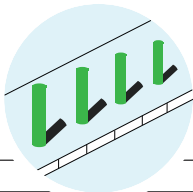

REMOVABLE MULLIONS

These are vertical structures used to separate and support multiple doors used for extra wide openings. The mullion(s) allow individual doors to be opened separately, or the full opening can be utilised by sliding the mullion(s) out of the way.



SWING DOORS

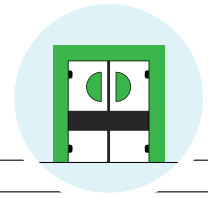

High standards of performance and durability, custom fit for your purpose & premises

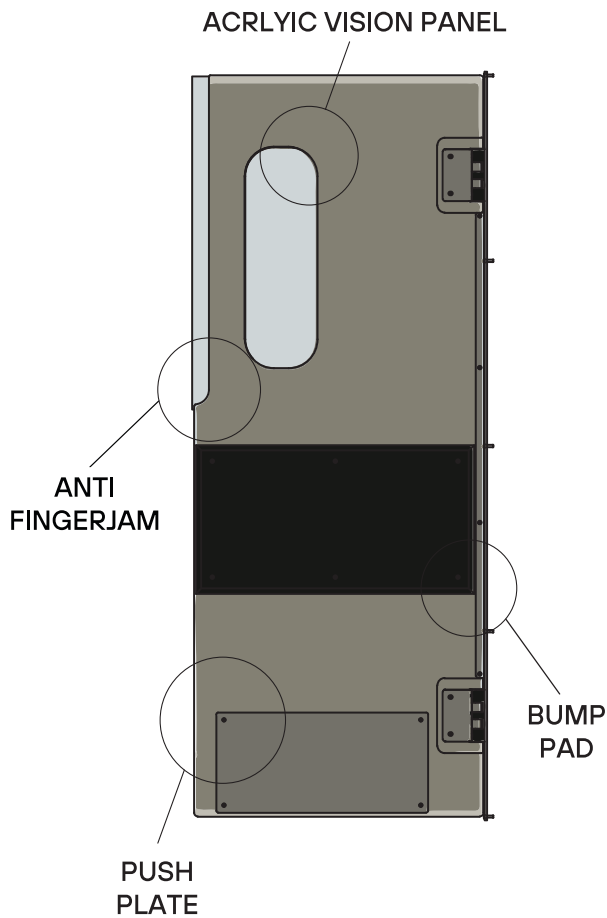

15MM WHITE HIGH DENSITY POLYETHYLENE

This durable hard plastic is recommended for high use areas, it is scratch and chemical resistant. The material can be washed with hot water to both sterilize and remove marks. It has a temperature rating from -30°C up to 90°C for short periods.

STAINLESS STEEL

All metal components and fasteners are stainless steel, making them perfect for high moisture areas. This also makes them ideal for sterile environments.

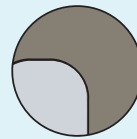

CLEAR ACRYLIC VISION PANELS

Vision panels allow a clear vision path through both sides of the door. Made with a strong and scratch resistant clear acrylic, it lessens the chance of doors being opened into people or objects.



3MM PVC ANTI FINGER JAM

This PVC Strip is to lessen the chance of fingers being jammed between door leaves or the door frame.



DOOR BUMP PANELS

Door bump panels provide extra protection from impact, but also allow doors to be bumped open with trolleys and other hard objects without damaging the door surface. This makes them preferable in food processing, warehousing & medical industries.

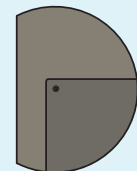

PUSH PLATES

Push Plates provide a durable surface that protects the door from damage caused by trolleys and carts, ensuring longevity in high-traffic areas. The Lower kick panel can either be 2mm Stainless Steel or HDPE spring pad, ensuring longevity and making them ideal for high-use areas such as industrial and commercial spaces.

SWING DOORS

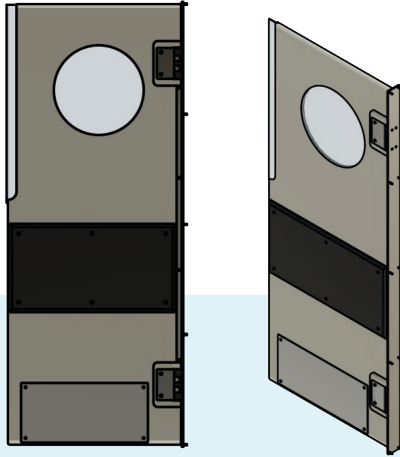
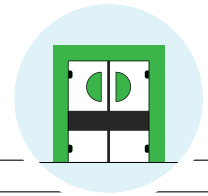

**SWING DOOR WITH
ROUND VISION PANEL**

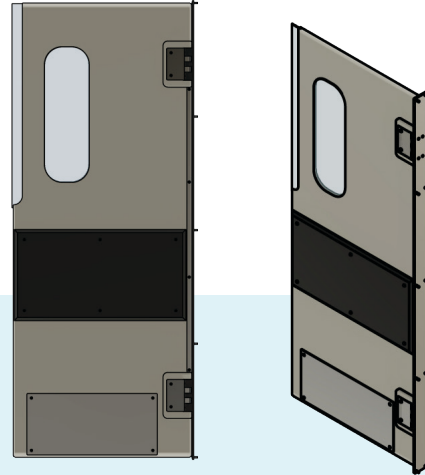

**SWING DOOR WITH
RECTANGLE VISION PANEL**

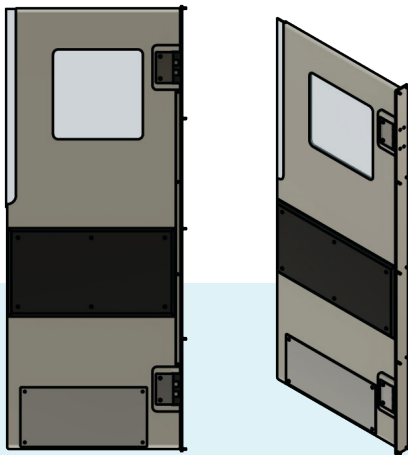

**SWING DOOR WITH
SQUARE VISION PANEL**

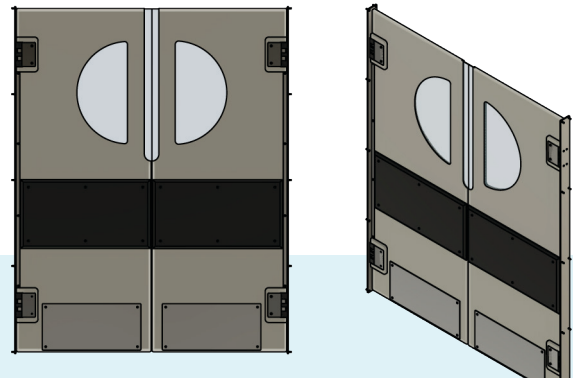

**SWING DOOR WITH DOUBLE
HALF ROUND VISION PANELS**

- Doors are manufactured in self-closing or hold open options.
- Maintenance free
- Doors can be manufactured up to 2400x2400
- Suitable for heavy duty continuous usage

- Made to measure
- Hinge tension can be adjusted for different operating conditions.
- With 30 years of door manufacturing experience
- All our swing doors are manufactured in Palmerston North

The industry-leading benchmark for quality, reliability and intelligence.



Grifco's global experience and innovation has resulted in industry leading designs and some of the most reliable and efficient products available here in New Zealand.

Users of Grifco equipment demand reliability and performance, but also expect intelligence in their door automation. Grifco operators work seamlessly within their building environments.

Whether they merely open a door, or enable a business to function, you can rest assured the intelligence and ease-of-integration of Grifco products are up to the challenge.

Grifco take compliance seriously and ensure that all products comply with ANZ 60335.2.1.2011 and 60335.2.103.2011 standards.

Each installation is completed with a commercial door and operator checklist, to be safe and to be sure.

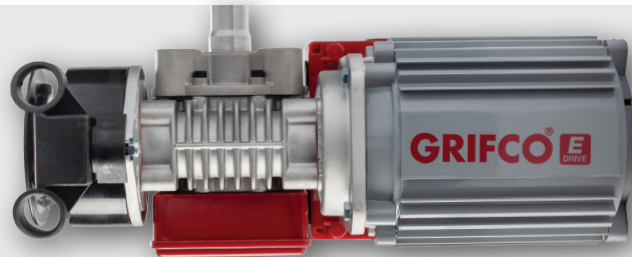

E-DRIVE

The Industry-Leading Operator for Spring-Balanced Roller Shutters and Grilles.



Grifco's E-Drive is the industry-standard for quality, durability and intelligence. With numerous models to select from (depending on door size and cycles) as well as multiple expansion options the E-Drive is the logical choice for automating spring-balanced roller shutters and grilles.

- Powerful range of motors with purpose designed gearbox for durable, reliable operation with purpose designed gearbox for durable, reliable operation
- Intelligent logic system for exceptional adaptability and integration into the building ecosystem. Optional expansion board for advanced functionality
- Automatic chain-engage mechanism for safe and easy manual operation in the absence of power
- Absolute Position Encoder for reliable door positioning and improved safety. Motor is disconnected the instant the manual hand chain is engaged



*myQ Gateway and Grifco Entrapment Protection System required (additional purchase).



- 📍 **Control from anywhere**
- 🔔 **Real-time notifications**
- 📅 **Preset scheduling**
- 🔑 **Access control**



POWERING STEVENSONS COMMERCIAL DOORS



LR-DRIVE

Operator for Light Commercial Roller Doors

Specifically designed for large and wind-locked roller doors. It is also ideal for shopfront roller grilles thanks to commercial terminals that allow dedicated open and closing.

- **Faster:** LR-Drive opens a 2.4m high door in only 21 seconds. Fastest in its class!
- **Stronger:** The powerful motor and gearbox can lift roller doors up to 28m² and wind-locked roller doors up to 22m²



- **Thinner:** The incredibly thin operator requires only 45mm of sideroom clearance
- **Smarter:** LR-Drive is myQ compatible* and features dedicated inputs for open / close and an OPEN Input

S-DRIVE

Operator for High-Cycle Sectional Doors

The industry standard. Purpose built for high-cycle, highly demanding commercial sectional doors found in car parks, emergency services buildings and commercial tenancies.

- Quiet, DC motor and purpose-designed gearbox deliver extremely smooth and fast door cycles, with soft start/stop
- Integral logic boards offer ultimate adaptability to meet the demanding needs of carpark applications



- Thoughtfully designed for low ceiling carpark applications, with a low profile, lockable enclosure
- Grifco S-Drive is myQ compatible* and features dedicated inputs for open/ close

HD-DRIVE

Hard-Working Heavy Duty Operators for Larger Spring-Balanced Roller Shutters

Grifco's HD portfolio is designed for large spring-balanced roller shutters up to 80m². It is also available in various specialised models, such as with a solenoid brake, water-resistant or explosion proof.

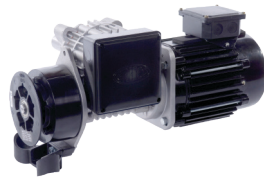

Fire Shutter Operators

Operator for Fire-Rated Spring-Balanced Roller Shutters

Grifco's unique portfolio of Fire Shutters are designed and tested to perform on spring-balanced fire-rated roller shutters. The innovative controlled-descent mechanism ensures a safe and reliable descent when instructed by the fire panel.



Controllers to suit a variety of applications

Grifco offer a broad range of standard and advanced controllers offering application-specific functionality and protection. Available in steel and plastic enclosures with numerous key switch options to suit your application.



Accessories

A wide selection of optional accessories



Wireless Visor Remote
E943G



Keyring Remote
E960G



Wireless Security Keypad
E840G



Wireless Keypad
E850G



myQ Internet Gateway
G828AU



Monitored Reflective Safety Beam
GPS15



Monitored Light Curtain System
GLCPS



Uninterrupted Power Supply
CSCT-2000

HIGH SPEED RAPIDS



Manufactured with quality components, and designed to withstand high-repetition use and significant wind loads.



HS35 MOVIDOR

Rapid roller door for medium doorways. Suited to interior and exterior use.

- Doorways up to 4000mmH x 4000mmW
- Heavy duty guides
- Integrated relocation system
- Multiple integrated wind battens
- Opening Speed 2.0m/sec.

MOVICHILL

Rapid roll up door for cool rooms and freezers.

- Doorways up to 4000mmH x 3000mmW
- Full surround brush seal for optimum seal against air-loss/gain
- Insulated and heated door frame with choice of curtain thickness
- Unique multi-layer insulated curtain with integrated thermal breaks and compression venting*
- Optional Interlock function for airlock applications
- Opening Speed up to 2.0m/sec

* Windows are not standard and not recommended in this model

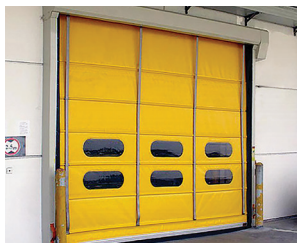

HIGH SPEED RAPIDS



Our range of activation systems and options offers optimal opening and a higher protection level for high speed rapids.

Activation Systems & Options

FALCON RADAR

Waterproof high performance sensor, discriminates vehicles from pedestrians and rejects the parallel traffic. The planar antenna provides accuracy and stability of the sensing field.



REMOTE CONTROLS

Multi-channel transmitters available. Receiver card integrated in control cabinet all allows several doors to be switched individually from one handset.

Movidor Colour Options

Choose from the below range of standard curtain colour options. Coordinate curtain colours with the façade of your building, or contact our friendly door specialists for customised printing and signage, as per your specifications.

Custom powder-coated aluminium framework also available in a variety of colours.

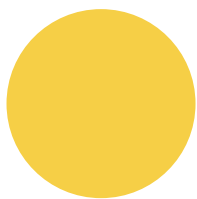

Yellow 119



Orange 224

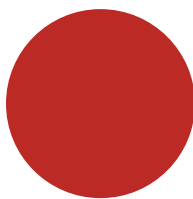

Red 356

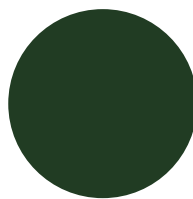

Dark Green 679

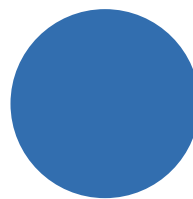

Light Blue 586

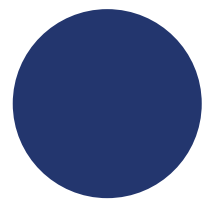

Blue 560

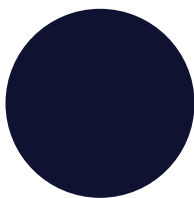

Navy 541

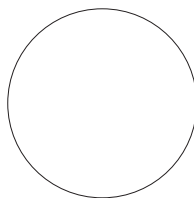

White 907

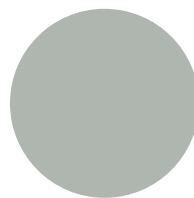

Grey 705

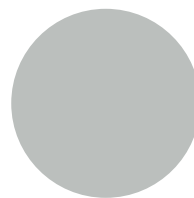

Light Grey 729

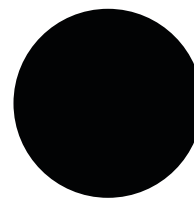

Black 905

ROLLER & RETRACTABLE GRILLES

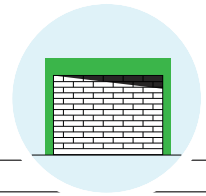

19MM ROLLER GRILLE

A practical solution for areas requiring security, high visibility or airflow. The attractive appearance is created using horizontal aluminium tubes. These are connected by nylon links, forming a sturdy brickwork pattern.

12MM ROLLER GRILLE

An optimal high security grille, composed of aluminium tubes connected by vertical aluminium links which forms an extremely strong brickwork pattern, perfectly integrating both style and strength. Both manual and motor options available.



ALUMINIUM ROLLER SHUTTER DOOR

Designed for a wide range of applications in areas that require concealment from view. The aluminium interlocking slats make this roller shutter dust and vermin proof, easy to clean and meets food hygiene standards, while still retaining an air of elegance.

POLYCARBONATE ROLLER SHUTTER DOOR

For areas where security and high levels of visibility combined with an attractive appearance is necessary. Clear polycarbonate slats with alternating aluminium joining rails allows for maximum vision and light, without allowing dust or vermin through.



SLIDING DOORS & GATES / HANGARS

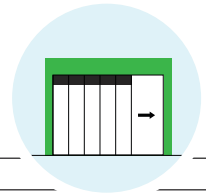

Available in both automatic and manual options, our sliding doors and gates are custom built to suit a wide range of applications and needs.



AUTOMATED OPTIONS

Automated sliding doors and gates can be supplied with smart operational technology including: safety beams, swipe card access, and auto opening and closing. The look of your gate can be customised to suit your preferred aesthetic. They operate both smoothly and quietly making them perfect for car parks and basements.



MANUAL OPTIONS

Manual sliding doors are a simple and effective way to create large openings in buildings where the overhead space is limited. With different selections of cladding including galvanisation, Coloursteel® and zinc. These doors are great for all types of factories, workshops, barns, airport hangars and plant / machinery rooms.



LIGHT COMMERCIAL DOORS

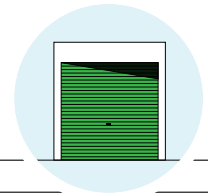

SERIES 2: Suitable for low wind zones and 4mx4m openings. Available in standard Coloursteel® finish.



Colour Options

With Colorsteel® we can create custom doors to suit your budget, environment, functionality and style.

NB: Colours shown are guides only, and are NOT true representative of actual colour.

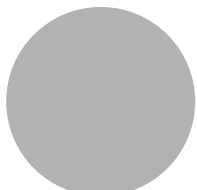

Gull Grey

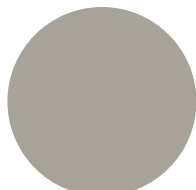

Sandstone Grey



Titania



Smooth Cream

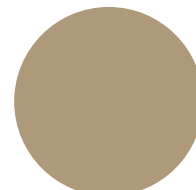

Desert Sand

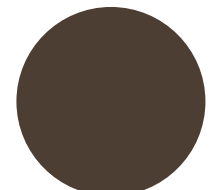

Lignite

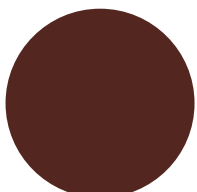

Scoria

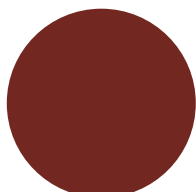

Pioneer Red

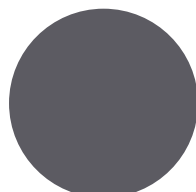

Grey Friars

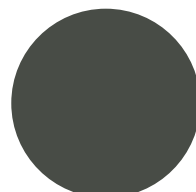

Thunder Grey

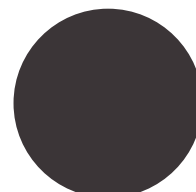

Iron Sand

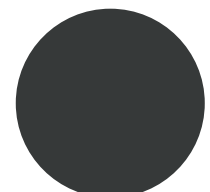

Flax Pod

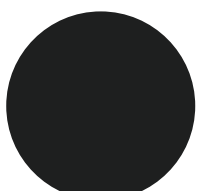

Ebony

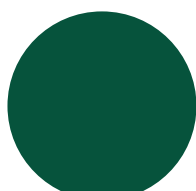

Permanent Green

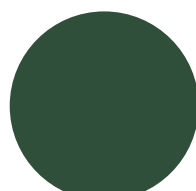

River Green

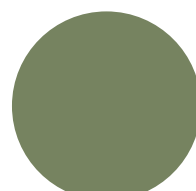

Mist Green

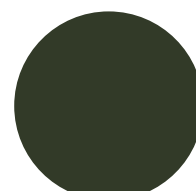

Karaka

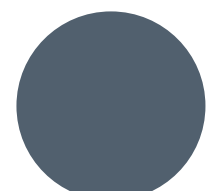

New Denim Blue

SERVICING & REPAIRS



24/7 0800 455 566

Get 24/7 responsive call-out repair service from an experienced technician

While doors are made to withstand plenty of regular use, accidents and wear-and-tear issues do happen. Maintain the security of your business, and your own peace of mind, with our prompt repair service.

- We service and repair all leading brands of roller shutters, auto, manual, swing, sliding doors and more.
- We aim to respond to urgent calls within the hour.

Extend the operational lifespan of your door with professional servicing

Maintain the operating performance, safety and reliability of your doors with a preventative maintenance programme. Regular servicing will significantly increase the lifespan of your doors, while also minimising the risk of breakdowns, along with the expense of downtime and repair.

We provide a thorough inspection, check, adjustment and lubrication, all as part of the service package. You'll receive a Service Report advising details of checks and adjustments made by our team, an assessment of the door

condition, recommendations and advance warnings of more costly repairs. Any additional repairs will be discussed and quoted.

- We can develop a regular service schedule based on your individual door types, usage frequency and requirements.
- Your doors are added to our database, helping ensure we maintain stocks of common parts and supplies.



INSTALL

We manufacture our own high-quality custom roller shutter doors, and have an experienced fleet of installers servicing the entire lower North Island.

REPAIR

Get your door up and rolling again with minimal downtime and inconvenience. We offer prompt emergency repair for your home or business.

SERVICE

Stay on top of regular wear and tear and keep your garage doors operating at their best. We service all makes and styles of electric and manual doors.

Head Office / Workshop / Depot
16-20 Admiral Place, Palmerston North
P +64 6 353 0808

Office / Workshop
Unit 5, 82 Main Road, Tawa, Wellington
P +64 4 568 9159

Depot
Napier / **FP 0800 455 566 / Ext 2**

E office@stevensonsdoors.co.nz W stevensonsdoors.co.nz

